

Appendix - C

GUIDELINES FOR OPGW CABLE LIVE-LINE INSTALLATION

1. General

Installation procedure for OPGW is basically similar to that for conventional overhead ground wires in overhead transmission line construction, however particular care required to be taken for protection of optical fibers in OPGW cable from damage by handling the same properly during transportation, unloading and installation at site. Live line installation to be carried out using traction machines and support rollers (hanging pully blocks) using experienced installation team comprising of minimum 30-35 persons. The installation team shall have one team leader/crew in-charge along with 15 skilled and 14 unskilled persons minimum in one installation crew.

List of Tools and Plants to be used are as per enclosed Annexure.

Following aspects are to be kept in mind before taking up live-line installation:

- a) Condition of existing ground wire for its suitability for live-line OPGW installation
- b) Tools and Plant suitability
- c) Weather Forecast for upto next 03 days to be considered before deployment/start of work in any section in consultation with POWERGRID Project Manager.
- d) Working conditions, specially following:
 - Strong winds more than 7 m/sec
 - Rain or snow
 - Foggy
 - Lightening
- e) These guidelines for live line installation along with checklist enclosed at Annexure-II to be provided in local language to the erection team.
- f) Pep talk snapshots & photos of erection team is to be shared with POWERGRID site as a regular practice.
- g) Team deployed for live line installation should have relevant experience of same or higher voltage level. Contractor to ensure the same.

2. Safety measures

All site workers must follow the Electricity Rules and Employer specified safety procedures. They must use safety belts, safety shoe, safety helmet and other safety items required.

Assign foremen/Crew In-charge for each erection crew for enforcing installation guidelines. It may be ensured that only authorized person is climbing the tower during live-line installation of OPGW. Fix the warning red flag on the tower, in order to keep the workers from encroaching into unsafe zones.

Frequent verification of healthiness of T&P and ropes shall be carried out before start of work.

2.1 **Permission to Work (PTW) :**

Permit to work to be obtained by the representative of installation agency from concerned sub-station staff in coordination with employer project manager prior to

commencement of installation and the same is to be returned after completion of the work in all respect within the specified time duly following the PTW conditions.

2.2 Preparedness to tackle untoward incidents:

- a) Safety Engineer has to make sure the availability of First Aid Box with each team.
- b) Maintain a record of the details of list of all nearby hospitals/clinics in each area, with contact details and Emergency contact nos. of Ambulances.
- c) In case of any untoward situation, Safety engineer/crew incharge must act fast and provide the necessary first aid to the affected person(s). Ambulance to be arranged immediately from the nearby area and coordinate with hospital for immediate medical assistance as required.

2.3 Marking of Zones during OPGW Stringing:

It is very essential for the installation agency to be aware of safe zones of the Tower while carrying out live-line installation. Generally crew members identified for preparation work on the ground, will not work on the tower and will remain within hazard-free zone.

The pictorial view of the working zone and limitation of the restricted zone are shown below for your convenience.

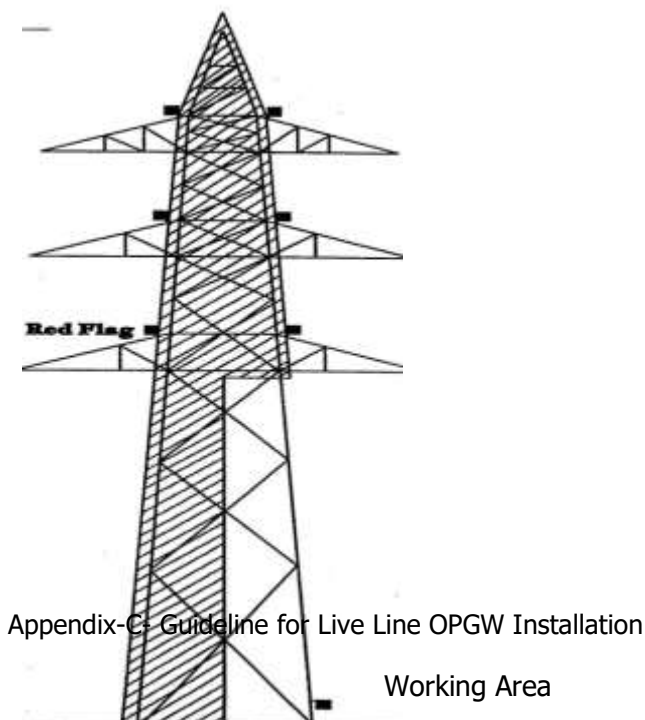

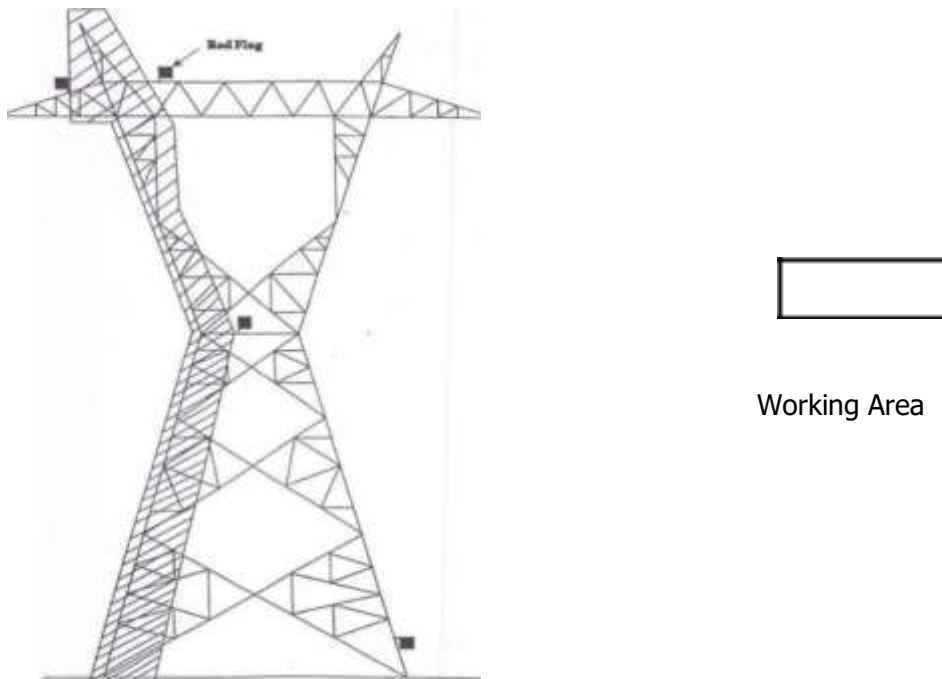

3. Grounding

Grounding of the following before starting work at site is required to be ensured.
Grounding devices include the following:

3.1 Equipment Grounding:

Equipment like OPGW and Existing Ground wire (GW), aerial rollers(pulley blocks) are connected with individual copper cable attached to the tower (with copper rod installed on the ground) or to the main grid if grounding system exists. Grounding clamp shall be cleaned well and ensure proper contact.

3.2 Running Ground:

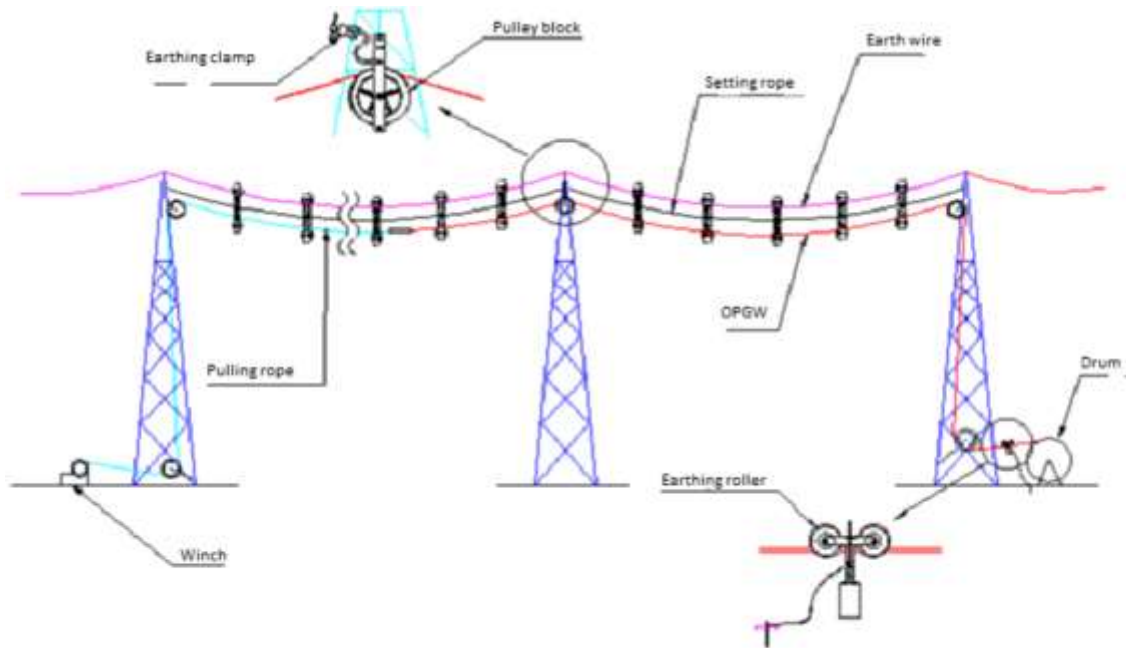

Running ground shall be installed on the OPGW at drum side during OPGW stringing time and at the Winch side on the existing GW during dismantling time for the whole stringing operation to avoid any electrical charges of induction from the line.

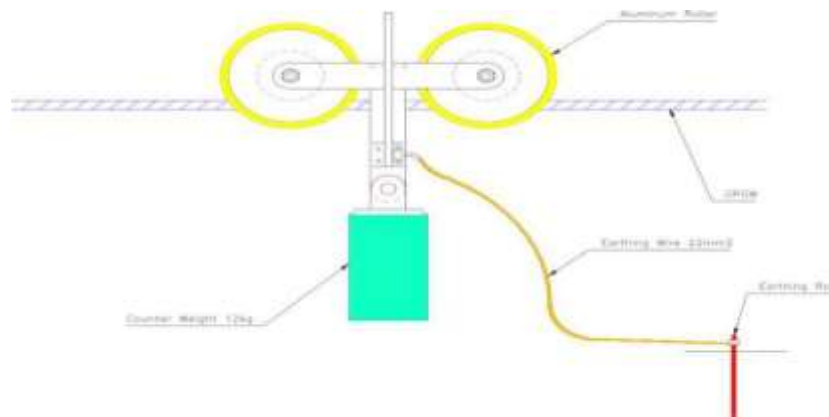

3.3 Pulley Block Grounding:

For each tower grounding type pulley block must be used.

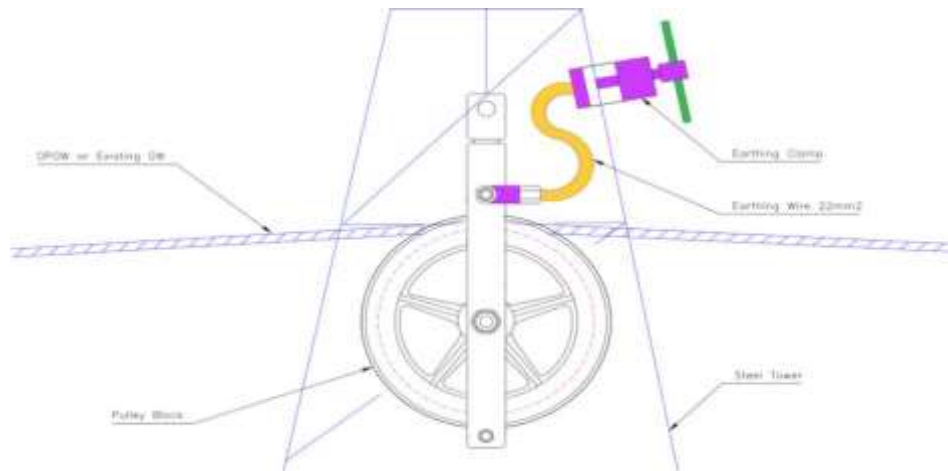

Grounding cable must be connected to the ground source first then to the object that needed to be grounded.

When removing grounds, the ground must be removed from the grounded objects first and then remove the grounding clamp from the ground source.

In case of any problems during the installation work, the person in charge of the section will immediately contact sub-station in charge of the line and employer Project Manager immediately for required support.

Further , in order to have proper earthing, one aluminum roller (hanging pulley block) shall be used for additional safety after every ten rollers (neoprene) used in the span/section.

4. Live-line Installation Process

4.1 Installation plan:

Following measures are to be taken in advance for smooth completion of the installation.

PTW availability and coordination with employer project manager

- Erection crew mobilization along with T&Ps
- Safety aspects
- Field quality aspects
- Transportation arrangement

4.2 Materials handling:

Check the material with respect to the approved documentation. All materials shall be visually examined for any physical damage. Any material, which is not as per documentation or is damaged, shall not be used.

OPGW Drums checks:

- Packing condition
- Packing list (Object, Type, Length, OPGW Weight, Drum No. etc)
- Attenuation results of OPGW

Hardware Fittings Checks:

- Bolts, Nuts Pitch
- Type & Quantity

Handling of OPGW:

OPGW contains optical fibers which are very delicate and to be handled with due care. For the safety of optical fibers, it is very important to avoid the bending at sharp angle. Manufacturer guidelines are to be followed strictly while handling the same. In order to avoid undue tension on OPGW, it is not recommended to pay off OPGW together with phase conductors or other wires tied in parallel. The tension during stringing works should be well managed within permissible limits. Adequate length of OPGW shall be ensured as loop at each joint location after stringing so that it is possible to bring OPGW up to the ground level for carrying out jointing work.

5. Clearance Checking

5.1 Check the clearance between existing ground-wire and live conductor before Stringing. Check the clearance between OPGW and live conductor. Minimum clearances as per as per pre-commissioning procedures for transmission lines is mentioned at **Annexure-III**.

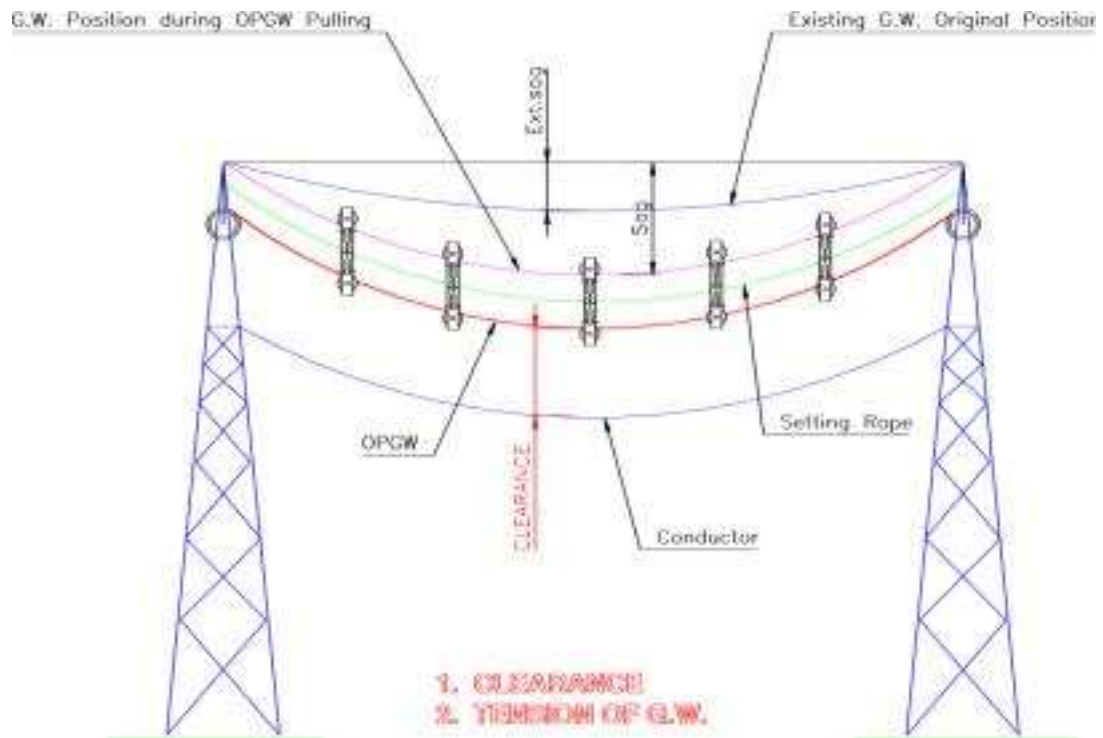

6. OPGW Stringing

- Removal of Aviation globules in the spans (wherever applicable) by taking proper shutdown.
 - Hang the pulley blocks on one of the earth wire peaks for the whole section (Section is a consecutive group of towers needed to support the installation of scheduled length of OPGW Drum)

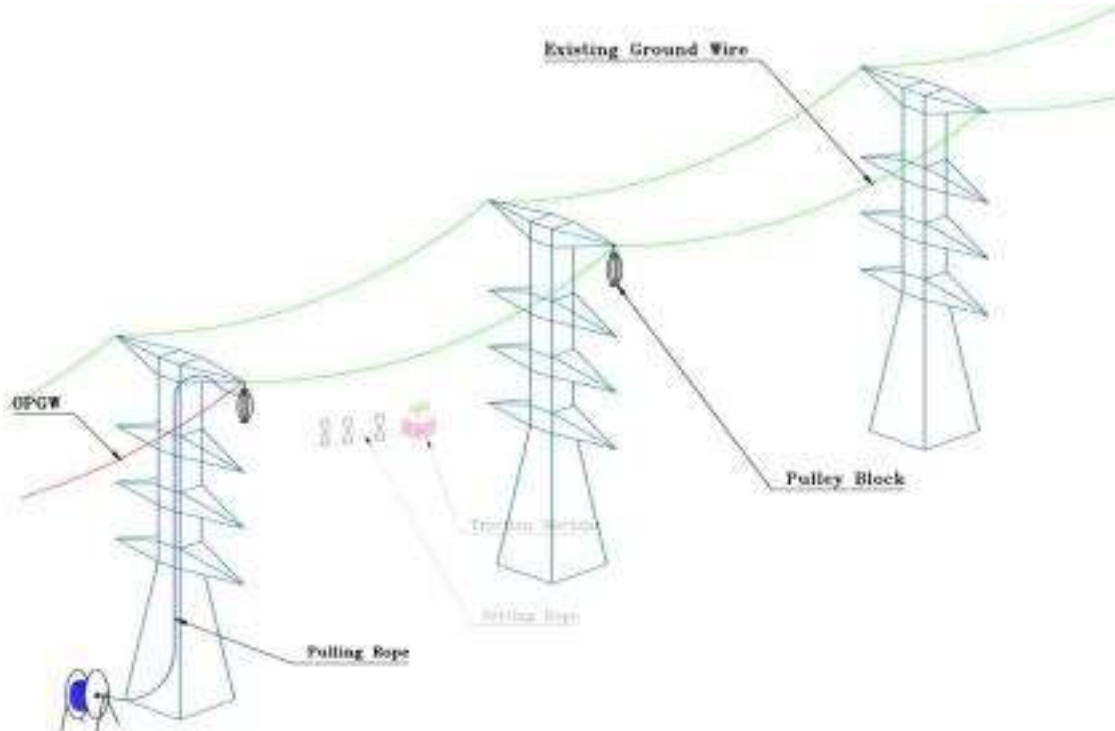

- Set the Traction machine on the existing ground wire.
- Set the support rollers (hanging pulley blocks) on the existing ground wire where the OPGW is to be installed.
- Connect the Setting Rope and Pulling Rope to the Traction Machine.
- Pull the support rollers (hanging pulley blocks), Setting Rope and Pulling Rope with the use of Traction Machine. Support rollers (Hanging Pulley blocks) should be hanged at an interval depending on voltage level, which is mentioned below. (A mark with these specified interval shall be marked on setting rope)

Sl.no	Voltage level	Spacing
1	220kV	18-22m
2	400kV	15-18m
3	765kV	10-12m

- For every ten support rollers (hanging pulley blocks) of neoprene used in the span/section, one aluminum roller (hanging pulley block) shall be used.
- Securing the pulling & setting rope at end towers of the stringing section.
- Connect the OPGW to the Pulling Rope with Stringing Clamp.
- Pull the Pulling Rope with the use of winch machine to pay out the OPGW.
- Set the Come-along and Lever Block to the existing ground wire.
- Release the tension of existing ground wire. At the same time, with a fixed come-along and Lever Block, give more tension to the OPGW.

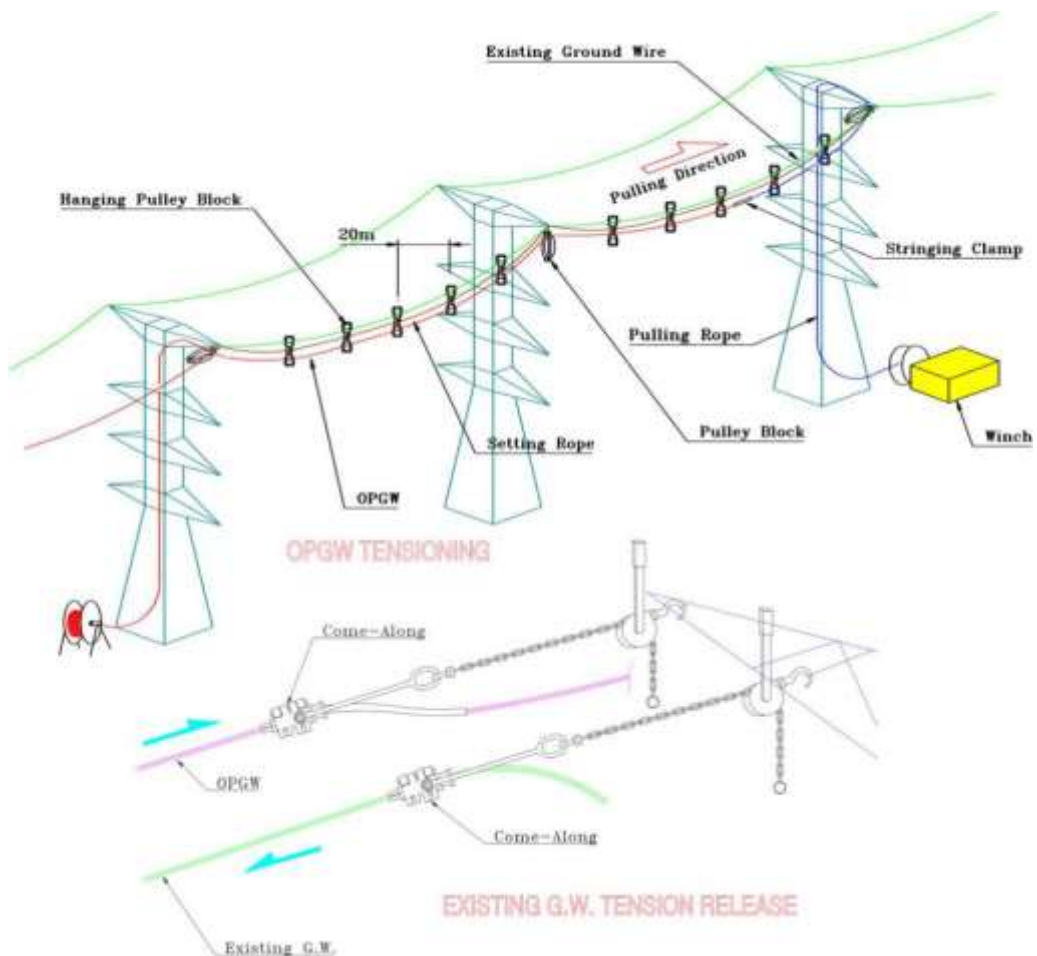

- Position of OPGW and existing ground wire will interchange with above action. The OPGW will be in upper position and existing ground wire in lower position in support rollers (hanging pulley blocks).
- With this OPGW paying for a section gets completed.
- Finally after successful stringing of OPGW and dismantling of Earthwire along with all ropes, support rollers etc., proper shutdown may be taken to install aviation globules back in the respective spans. The installing agency to ensure healthiness of all ropes and T&Ps used for the stringing work.

Additional suggestive measures:

(a) Loosening of earth wire to be avoided.

(b) Cradle blocks of Aluminum type to be preferably used in 765kV lines as per placement recommended in the guidelines.

Special Provisions in case of inclement weather:

In case of sudden change in weather/possibility of rain, fog, storm etc coming to notice during stringing, the contractor may explore feasibility of pulling OPGW in possible sections and removal of pulleys/ropes etc from balance sections of drum. Use of approved Tension fitting (pass through) for Suspension tower (Yoke plate) for tension clamping of OPGW as an interim arrangement may be explored. This aspect may be used to facilitate removal of pulleys and ropes from all sections to avoid tripping of lines occurring in bad weather. This provision may be explored to limit the exposure of T&Ps/ropes/pulleys used in Live Line OPGW stringing during such bad weather to live line. This is to be done in consultation with Project Manager. This does not limit the contracting agencies from taking measures to avoid trippings of line and ensuring safety of their personnel.

7. Dismantling process

7.1 Existing ground wire:

- Connect the existing ground wire with the Pulling Rope.
- Pull the Pulling Rope with winch to dismantle the ground wire.

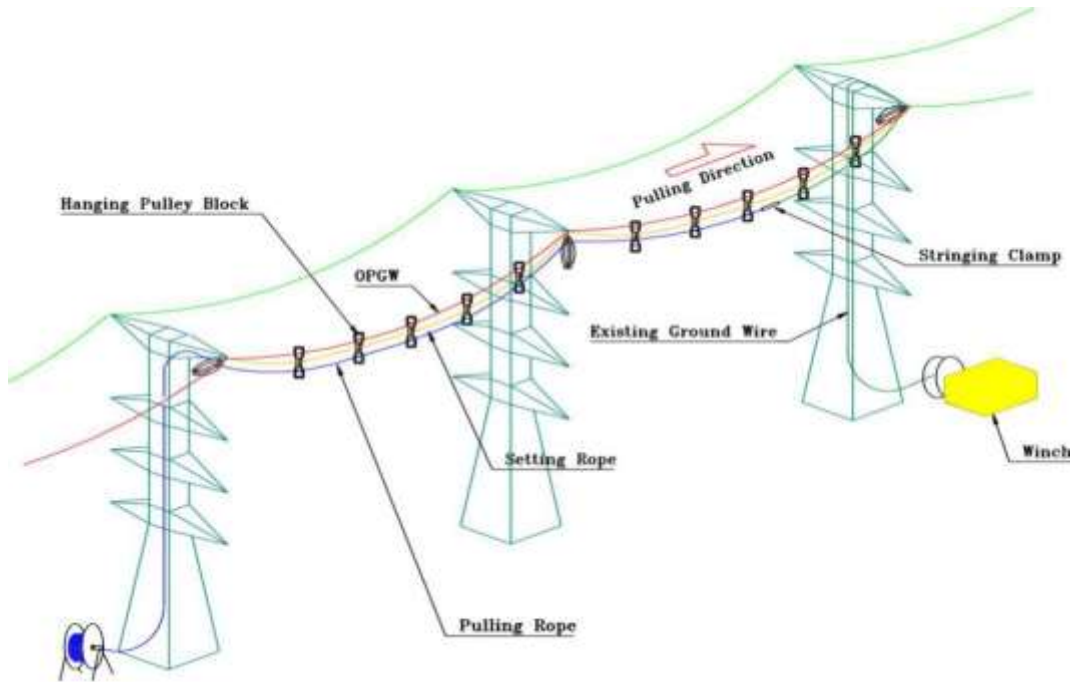

7.2 Hanging Pulley Block, Setting Rope and Pulling Rope:

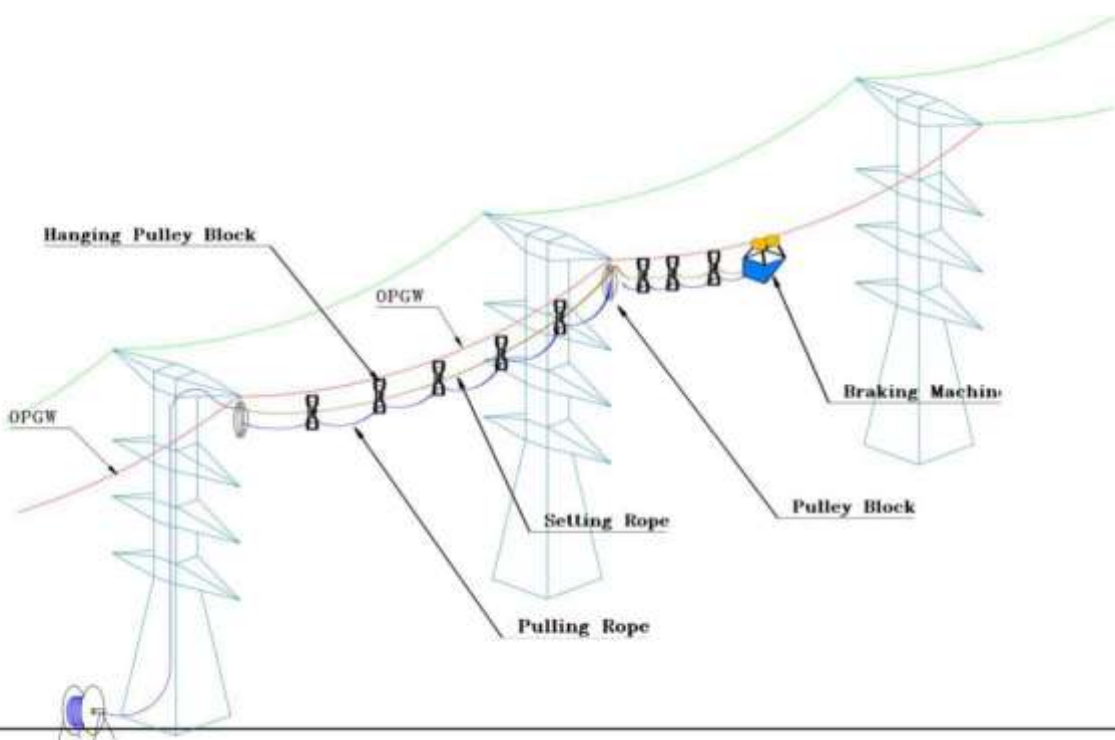

- Set the Breaking Machine on the OPGW of the span required for dismantling.
- Connect the Pulling Rope and Setting Rope to the Braking Machine.
- Pull the Setting Rope and Pulling Rope to dismantle.

Collect and dismantle the support rollers (hanging pulley blocks) upon reaching the succeeding tower.

8. OPGW sagging

- Use the pre-calculated Sag & Tension Table as sag reference.
- Avoid fixing the sag if the wind is strong.

8.1 Sagging:

1) Methods and procedures for sagging of OPGW are the same as those of normal overhead ground wire.

2) After stringing the OPGW shall be sagged using information furnished on the sag and tension chart. The sag of the OPGW should not exceed the existing ground-wire sag.

3) Sagging thermometers shall be used to determine accurate temperature and OPGW sag of each sag section. Sagging thermometer shall be used sufficiently prior to the actual sagging operation to represent the temperature of the OPGW.

5) At the time of sagging OPGW, the sag should be within 6 inches of the theoretical value for existing temperature condition.

7) OPGW tension between each sag section shall be equalized and this shall be determined by the vertical position of the suspension clamps on the last clipped structure of the preceding sag section.

8) For pulling the OPGW with tension, the device of come-along is to be recommended.

9) Personnel should be specifically deployed for keeping watch on sag at a different section of the line during live line stringing.

10) Waterproof caps shall be fixed at both ends of the OPGW cable after installation.

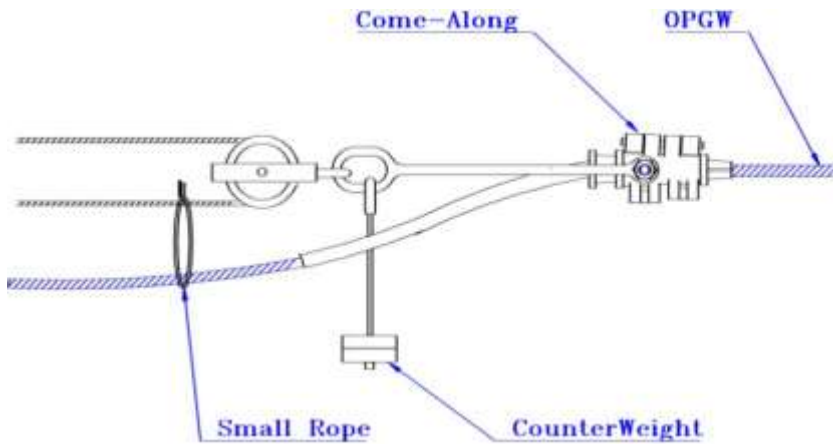

9. OPGW Clamping

- 9.1 Make sure to install and tighten the bolt of clamp properly.
- 9.2 Tightening must be made sequentially from the support point.

TENSION TOWER

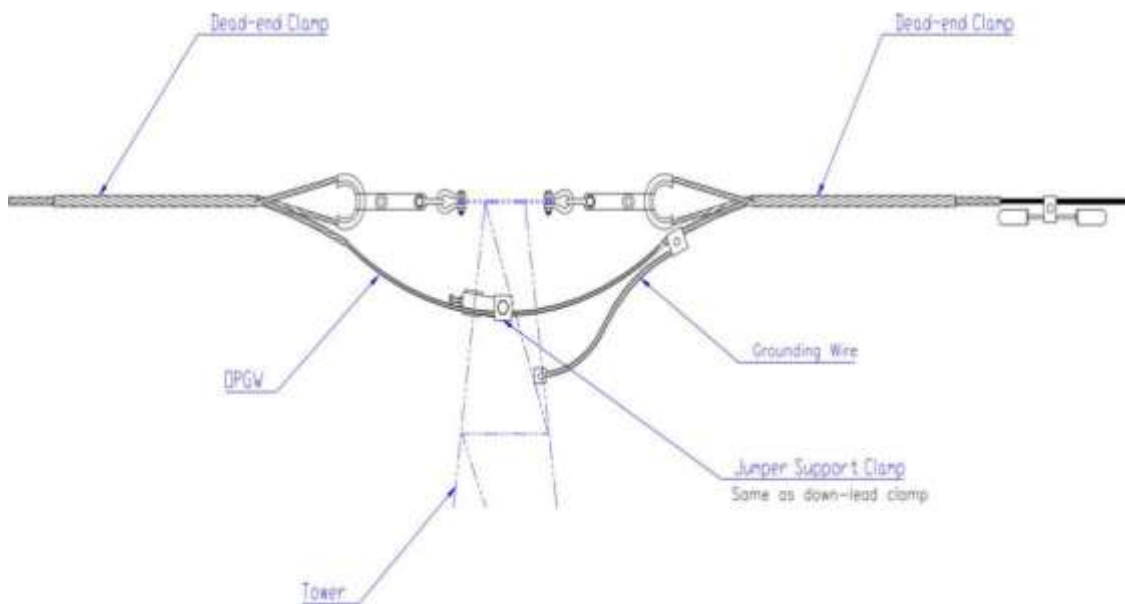

SUSPENSION TOWER

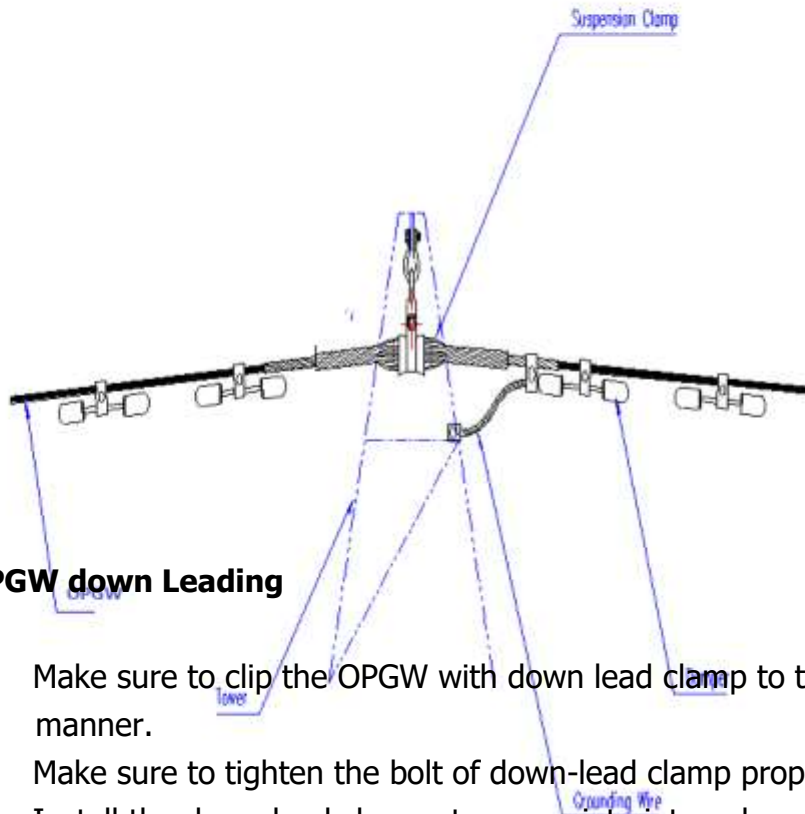

10. OPGW down Leading

- 10.1 Make sure to clip the OPGW with down lead clamp to the tower in a careful manner.
- 10.2 Make sure to tighten the bolt of down-lead clamp properly.
- 10.3 Install the down-lead clamp at appropriate interval .

SUSPENSION TOWER FOR JOINTING TOWER

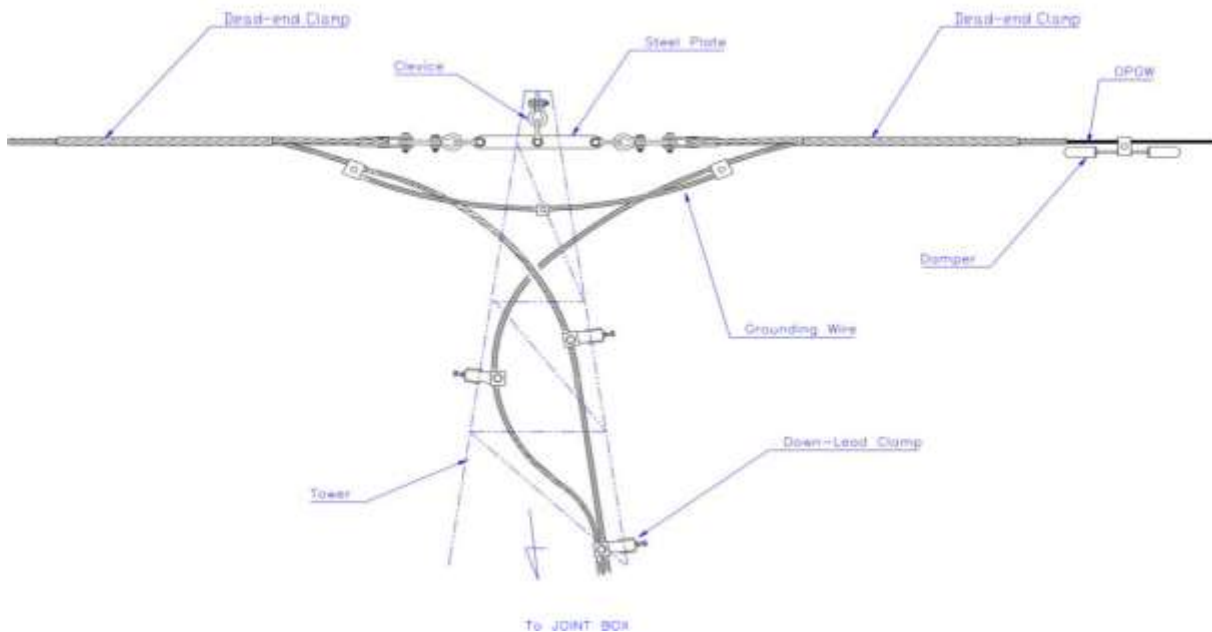

TENSION TOWER OF JOINTING TOWER

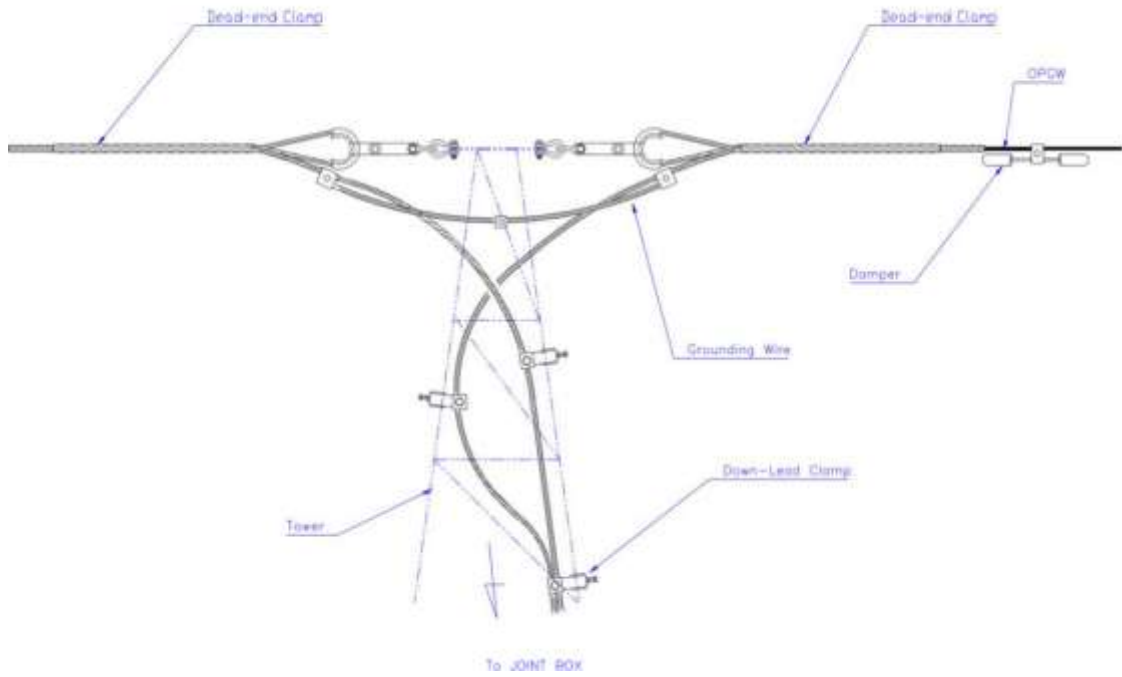

Annexure-1

List of Tools:

S. No	Description	Specifications
01	Aerial Roller/Pulley Block (Aluminum)	300 mm
02	Aerial Roller/Pulley Block (Aluminum)	450 mm
03	Aerial Roller/Pulley Block (Aluminum)	600 mm
04	Setting rope	12 mm PP rope Rope
05	Pulling Rope	(i)For Preparation: a) 12mm PP Rope Rope (for 400kv and above); b) 12mm Nylon rope(for 220kv & below) (ii)For OPGW Pulling: 14mm Nylon rope
06	Lifting/Supporting Rope	12mm PP rope
07	Earthing roller	3-way roller
08	Traction machine	35 kgf
09	Winch machine	3 tons
10	Drum stand	
11	Wheel winder	
12	Come along clamp	
13	Kitto clamp	
14	D-shackle	
15	Sag-scope	
16	Support Rollers (Hanging Pulley block)	
17	Aluminium Roller (Aluminium Hanging Pulley Block)	
18	Earthing Lead	
19	Braking Machine	

Annexure-II Check List for OPGW stringing work (Frequency-Daily)

SL No	Check Point	Remarks
Before Start of Work		
1.	PTW is available	Yes/No
2.	Awareness among working gang on live-line installation procedure	Yes/No
3.	All Tool and plants are duly tested and certificates are available including healthiness of ropes.	Yes/No
4.	Weather condition is good i.e. No heavy wind/Lightning/Fog/rain/snow etc.	Yes/No
5.	First aid box is available	Yes/No
6.	Contact details of nearby Hospital is available	Yes/No
7.	Pep talk about OPGW stringing and safety requirement given	Yes/No
8.	Tower climbing persons certified for height work	Yes/No
9.	There is no aviation globule in the EW <i>(Note: aviation globule exist shutdown to be taken for its removal before hotline stringing. Similarly, after installation OPGW shutdown need to be taken for installation of aviation globule)</i>	Yes/No
10.	OPGW drum schedule is available	Yes/No
11.	There shouldn't be any uneven joint/twist/broken strands in the earth wire between stringing span.	Ensured/Not ensured
12.	Tower Footing Resistance(TFR) check as per Asset Management norms of POWERGRID. (In case of poor TFR, to be intimated to POWERGRID)	Ensure/Not Ensured
During Work		
1.	Clearance of EW to Top conductor is adequate i.e. 9 meters (for 400kV and 765 kV system),8.5 meter for 220kV system	Ok/Not OK
2.	Running ground is installed on the OPGW at drum side during stringing (To neutralize the induction effect during stringing)	Yes/No
3.	Tension during stringing is within limit to avoid breakage of OPGW/PP rope	Ensured/Not ensured
4.	Support rollers (hanging pulley blocks) should be hanged at an interval of 18-22 meter for 220kV level,15-18 meter in 400kV level and 10-12 meter for 765kV Level	Ensured/Not ensured
5.	For every ten support rollers of neoprene one aluminum roller shall be used	Yes/No
6.	Pulling and setting rope is secured at the end of Tower of stringing section.	Ensured/Not ensured
7.	Sag of OPGW is equal to existing EW sag (it shouldn't be more than that)	Ensured/Not ensured
8.	Proper clamping of down lead clamp at appropriate interval is done at the jointing Tower (either Suspension/tension)	Ensured/Not ensured
9.	Healthiness of ropes	Ensured/Not ensured
After completion of stringing work/each day target		
1.	There should not be any loose PP rope in the stringing span after completion of each day work. It should be tightened properly.	Ensured/Not ensured

2.	After final stringing Mid span clearance is adequate i.e. 9 meters (for 400kV and 765 kV system),8.5 meter for 220kV system (Actual value needs to be recorded for future purpose)	Ensured/Not ensured

Annexure-III MINIMUM CLEARANCES AS PER PRE-COMMISSIONING PROCEDURES FOR TRANSMISSION LINES

Electrical Clearance

All statutory electrical clearance of transmission lines w.r.t. ground, building, Structures, Power line crossings, River crossing, Railway & Road crossings etc. as stipulated under latest version of Central Electricity Authority (Measures relating to Safety and Electric Supply) Regulations & POWERGRID specification shall be ensured.

Minimum Ground clearance shall be as per clause 58.0 of Central Electricity Authority (Measures relating to Safety and Electric Supply) Regulations, 2010.

The ground profile at the time of commissioning shall be checked with the profile approved at the time of check survey.

Sag in one of the span in each section shall be measured and it should be ensured that sag & tension of the section is in line with specification and sag & tension calculation chart approved by Engg.

Ground clearance of lowest conductors at critical points shall be checked in the field from any of the prevalent method and the values of ground clearance at these critical points including all power line, railway line and road crossings shall be recorded in the prescribed format.

In case of hilly Terrain and for building clearance, the side clearance from conductors and jumpers at critical points shall also be checked and recorded for all phases of conductor/ earth wire/ OPGW towards hill building side.

Transmission voltage (in kV)	66	132	220	± 320 HVDC	400	765	± 500 HVDC	± 800 HVDC	1200
Minimum Ground Clearance (in meter)	5.5	6.1	7.015	8.5	8.84	18	12.5	18	24

Clearance of earth wire/OPGW with Top conductor at mid span to Top conductor

Availability of required vertical clearances (as per design & POWERGRID Specification) between conductor and earth wire/OPGW shall be ensured through random checking. Minimum clearances between conductor and earth wire/OPGW at mid-span shall be as indicated:

Voltage (kV)	66	132	220	+/- 320 HVDC	400	+/- 500 HVDC	765	+/- 800 HVDC	1200
Minimum mid span clearance (in meter)	3	6.1	8.5	8.5	9	9	9	12(pole) 6.1(DMR)	18

Record of such random checks shall be the part of pre-commissioning records.

Clearance between line crossings each other, the minimum clearances between the Power line crossing each other shall be as per clause no 69.0, part-III, Sec-4 of CEA's Regulations 2010 (Measures relating to Safety and Electric Supply)

Where an overhead line crosses another overhead line, clearances shall be as under:

(Minimum clearances in meters between AC lines crossing each other)

Sl. No.	Nominal System Voltage (kV)	11-66	110-132	220	400	765	1200
1.	Low and Medium	2.44	3.05	4.58	5.49	7.94	10.44
2.	11-66	2.44	3.05	4.58	5.49	7.94	10.44
3.	110-132	3.05	3.05	4.58	5.49	7.94	10.44
4.	220	4.58	4.58	4.58	5.49	7.94	10.44
5.	400	5.49	5.49	5.49	5.49	7.94	10.44
6.	765	7.94	7.94	7.94	7.94	7.94	10.44
7.	1200	10.44	10.44	10.44	10.44	10.44	10.44

Where an overhead direct current (DC) line crosses another overhead line, clearances shall be as under: -

Minimum clearances in meters between AC and DC lines crossing each other

Sl. No.	System Voltage (AC/DC)	100 kV DC	200 kV DC	300 kV DC	400 kV DC	500 kV DC	600 kV DC	800 kV DC
1	Low and Medium AC	3.05	4.71	5.32	6.04	6.79	7.54	9.04
2	11-66 kV AC	3.05	4.71	5.32	6.04	6.79	7.54	9.04
3	110-132 kV AC	3.05	4.71	5.32	6.04	6.79	7.54	9.04
4	220 kV AC	4.58	4.71	5.32	6.04	6.79	7.54	9.04
5	200 kV DC	4.71	4.71	5.32	6.04	6.79	7.54	9.04
6	300 kV AC	5.32	5.32	5.32	6.04	6.79	7.54	9.04
7	400 kV AC	5.49	5.49	5.49	6.04	6.79	7.54	9.04
8	400 kV DC	6.04	6.04	6.04	6.04	6.79	7.54	9.04
9	500 kV DC	6.79	6.79	6.79	6.79	6.79	7.54	9.04
10	600 kV DC	7.54	7.54	7.54	7.54	7.54	7.54	9.04
11	765 kV AC	7.94	7.94	7.94	7.94	7.94	7.94	9.04
12	800 kV DC	9.04	9.04	9.04	9.04	9.04	9.04	9.04
13	1200 kV AC	10.44	10.44	10.44	10.44	10.44	10.44	10.44

Provided that no guarding are required when line of voltage exceeding 33 kV crosses over another line of 250 V and above voltage or a road or a tram subject to the condition that adequate clearances are provided between the lowest conductor of the line of voltage exceeding 33 kV and the top most conductor of the overhead line crossing underneath the line of voltage exceeding 33 kV and the clearances as stipulated in regulation 58 from the topmost surface of the road maintained